

"OPTION PLANCHA"

LAE 010 TPK

WARNING : If the information in this manual is not followed exactly, a fire or explosion may result causing property damage, personal injury or death.

- Do not store or use gasoline or other flammable vapors and liquids in the vicinity of this or any other appliance.
- **WHAT TO DO IF YOU SMELL GAS.**
 - Do not try to light any appliance.
 - Do not touch any electrical switch.
 - Do not use any phone in your building.
 - Immediately call your gas supplier from a neighbor's phone. Follow the gas supplier's instructions.
 - If you cannot reach your gas supplier, call the fire department.
- Installation and service must be performed by a qualified installer, service agency or the gas supplier.



WARNING :
THIS RANGE CAN TIP
INJURY TO PERSONS COULD RESULT
INSTALL ANTI-TIP DEVICE PACKED
WITH RANGE
SEE INSTALLATION INSTRUCTIONS





GENERAL MANUAL

LAE 010 TPK

Layout :

Optional plate, smooth grill plate to the left or right of the central cooking surface

Description :

Plancha mild-steel .

Dimensions 515 mm x 360 mm.

35-micron satin-finish chrome coating.

The heat is generated by a 2,2 kW resistor, controlled by the thermostat.

Limit-control plate protection.

Accessories :

Removable anti-splash screen.

A scraper.

Shipment / Packaging :

Unpack and check the appliance is in good condition. In case damage, note any reservations on the delivery note and confirm them within 48 hours by registered letter with confirmation of delivery to the carrier.

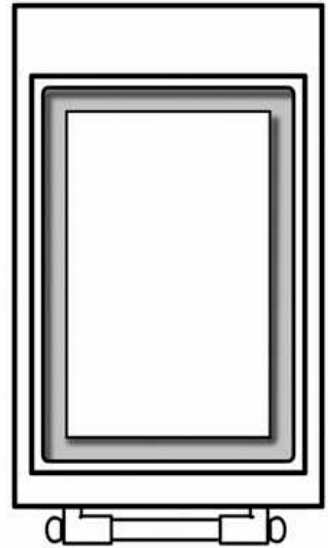

Item No.	P	U
LAE 010 TPK	2,2 kW	230 V1N~ 60 Hz + T / E

LAE 010 TPK

INSTALLER'S MANUAL

Appliances must be installed in a workmanlike manner in accordance with the instructions in this manual and locally applicable regulations.

This manual will be handed over to the user after installation.







INSTALLER'S MANUAL

LAE 010 TPK

IMPORTANT

- **Must be installed under an exhaust hood.**
- **Do not install this unit near combustible walls, partitions, pieces of furniture or decorative material unless these are covered with adequate thermal insulation of the noncombustible type.**
- **Making sure the resulting installation meets fire regulations.**

IMPORTANT

- **THE APPLIANCE MUST BE INSTALLED IN ACCORDANCE WITH THE LOCAL CODES OR *National Fuel Gas Code, ANSI Z223.1 or latest edition.***

IMPORTANT

- **Manual shut-off valve should be installed in an accessible location in the gas piping external to the appliance for the purpose of turning on or shutting off gas to the appliance.**



INSTALLER'S MANUAL

LAE 010 TPK

ELECTRICITY

➤ **ALL WORK ON OR REPAIR OF AN APPLIANCE MUST BE CARRIED OUT BY A QUALIFIED INSTALLER.**

➤ **THE APPLIANCE WHEN INSTALLED, MUST BE ELECTRICALLY GROUNDED IN ACCORDANCE WITH THE LOCAL CODES OR *The National Electrical Code, ANSI/NFPA 70-1996 or latest edition.***



It is hazardous to put the appliance into service without connecting it to suitable ground.

No liability can be accepted for accidents resulting from non-compliance with this requirement or incorrect grounding. Connect the equipotential bonding terminal (N, Figure 1)

☞ **Before connection, check that the :**

Mains voltage is compatible with the appliance's rated voltage and thermal output.

IMPORTANT

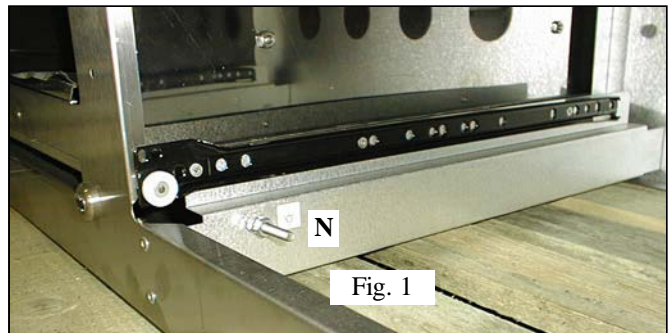

☞ **Connection :**

- Use a 3-wire grounded cord rated for 13 A or 4-wire rated for 30 A 125 / 250 VAC, type SRD, SRDT, S, SO or ST.
- Where local Codes do not permit grounding through neutral, use a 4-wire power supply cord or "pigtail" kit. Cord must be agency approved for use with household ranges.
- Remove access door **O** (Figure.2 gas oven range) or **P** (Figure 3 gas and electric range).
- Connect to terminal block in accordance with figure 4
- Secure the cable by means of cable clamp, item **Q** (Figure 4)
- Refit access door



INSTALLER'S MANUAL

LAE 010 TPK

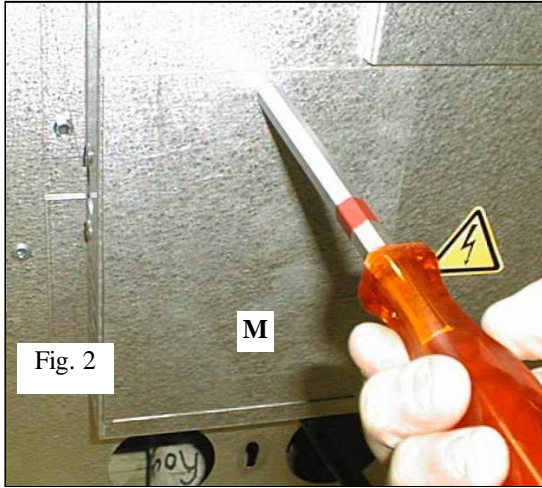
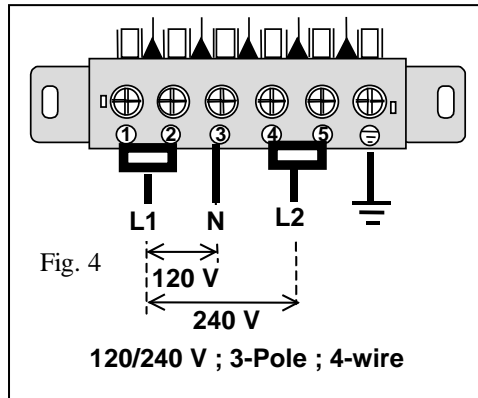

Fig. 2



Fig. 3





INSTALLER'S MANUAL

LAE 010 TPK

SERVICE INSTRUCTIONS :

All work on or repair of an appliance must be carried out by a qualified installer.

Limiting thermostat :

In accordance with the construction regulations, the limiter thermostat is intended to protect the range from overheating. In the event of overheating the limiter thermostat is triggered and cuts out the range's oven functions.

The advanced technology used in the limiter means that it is very sensitive to impacts and vibration that may occur during transport and handling.

The limiter may therefore be unexpectedly triggered when the plancha is first heated and stop the plancha from working.

To reset limiting thermostat :

- 1- Lift the top.
- 2- Push button rep. P

ALWAYS IDENTIFY the reason why the thermostat tripped.

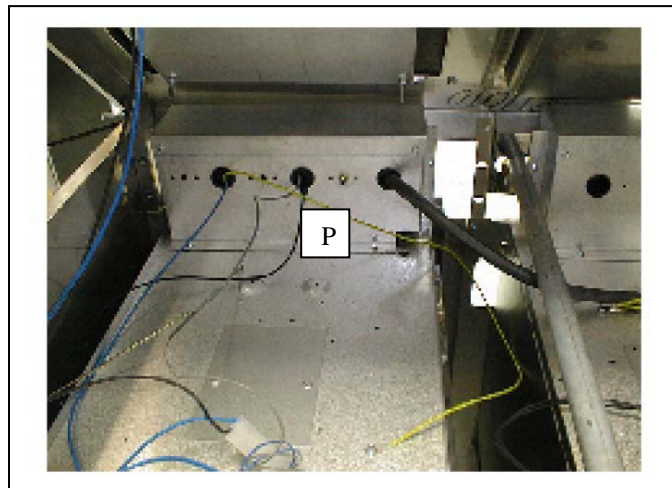



INSTALLER'S MANUAL

LAE 010 TPK

ELECTRIC CIRCUIT DIAGRAMMES

Rep / Item n°	Désignation / Designation	Référence / Part number
TL	Three pole limiting thermostat	65.38562
TH	Oven thermostat	65.38102
S	Switch	65.222012
R	Heating element	65.211016
H	Orange Lamp	65.231007

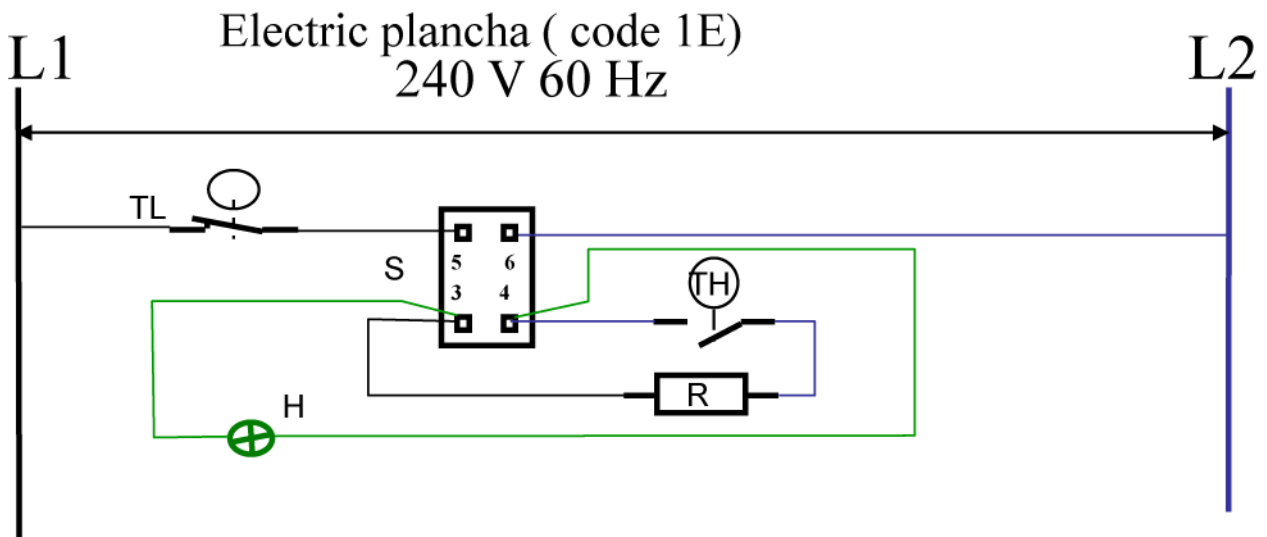

« *LACANCHE* »

USER'S MANUAL

IMPORTANT

Provide adequate air supply during use of the appliance.

Provide adequate clearances for servicing and proper operation by not obstructing front or side of appliances.

WARRANTY

The warranty is stated on the sales contract.

Please contact your approved Dealer if any work has to be carried out under warranty.

This warranty excludes damage resulting from incorrect installation, improper use or inadequate servicing.







USER'S MANUAL

LAE 010 TPK

SAFETY INSTRUCTIONS



- **If the range is to be installed on an area covered with linoleum or any other floor covering, make sure that the floor covering can withstand 90 F (65°C) above room temperature without warping, shrinking or discoloring. Do not install the range over carpeting.**
- **Never store anything in the oven or the cooktop. Flammable materials can catch fire, plastic items may melt or ignite and other types of items could be ruined.**
- **This appliance is for cooking. Based on safety considerations, never use the oven or cooktop to warm or heat a room. Doing so may result in carbon monoxide poisoning and overheating of the oven. Also, such use can damage the cooktop or oven parts.**
- **Never corver any slots, holes or passages in the oven bottom or cover an entire rack with materials such as aluminium foil. Doing so blocks air flow through the oven and may cause carbon monoxide poisoning.
Aluminium foil linings may also trap heat, causing a fire hazard.**
- **Do not obstruct the flow of combustion or ventilation air to the appliance. Be sure a fresh air supply is available.**
- **When using the cooktop, do not touch the burner grates or the immediate surrounding area. Areas adjacent to the burners may become hot enough to cause burns.**
- **Do not hang articles from any part of the appliance or place anything against the oven. Some fabrics are quite flammable and may catch on fire.**
- **However, children should not be left alone in the kitchen while the range is in use. Do not store items of interest to children over the unit. Children climbing to reach items could be seriously injured.**
- **Do not use aluminum foil to line any part of the oven or cooktop.**
- **When using the oven, do not touch the interior surfaces of the oven, the exterior area immediately surrounding the door or the backtrim.**
- **Disconnect from power supply before servicing.**



USER'S MANUAL

LAE 010 TPK

Before using for the first time

Remove the plastic protection.

Initial usage will cause some smoke and is no cause for alarm.

CAUTION : Potential users that temperatures may exceed 500 °F. Warn potential users of hazards involved.

Use :

Signal lamp A lights when the unit is energised.

Toggle switch B.

Turn the control knob to the desired position.

To shut down, turn dial clockwise, then toggle switch.

Recommandations :

Oil griddle prior to use with a good quality vegetable oil, a few seconds before cooking begins.

Plancha is perfect for :

- pieces of meat (steaks, chops, sirloin steaks, medallions, meatballs, Chinese-style meat, etc.)
- fish (fillets, lobsters and prawns, sardines, salmon and other fish steaks, etc.). We recommend you flour cod, hake, etc. type filets and use the cover (optional) to finish the cooking. For fish seared on one side (filet with one side skin), cook them on the skin side without turning them over.
- even vegetables (thinly sliced vegetables such as leeks, mushrooms, peppers, courgettes, etc.)

For successive cooking operations use the scraper to remove any residue from the heating area.

To avoid scratches we advise against cutting food directly on the pan.

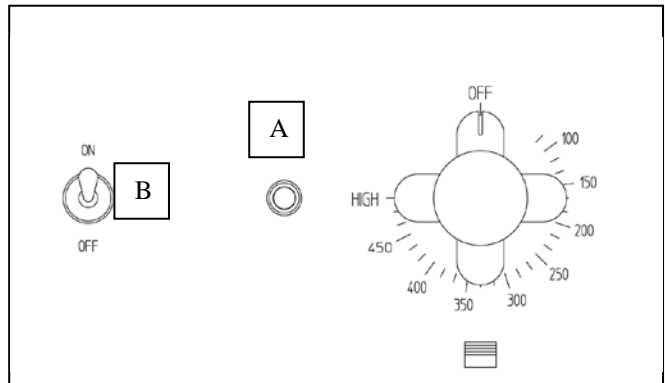

CAUTION Keep an eye on the plancha when it is in use



USER'S MANUAL

LAE 010 TPK

Information on the cooking time :

		Thermostat	Cooking time
Fish and shellfish	Fresh floured hake filets	450	3 min
	Cod filets	450	5 min
	Trout filet seared on one side, cooking finished under the cover	450	1 min 30
	Whole trout	450	11 min 30
	Fresh prawns	450	8 min
Meat	Fresh calf liver	400	3 min
	Pork chops, cooking finished under the cover	Hight	6 min 30
	Minced beef	Hight	3 min 30
	Whole steak	Hight	3 min 30
Vegetables	Finely chopped egetables, cooking under the cover : Carrots, onions, peppers	300	20 min
	Diced potato	300	20 min

(values stated for information only)



USER'S MANUAL

LAE 010 TPK

CLEANING

BEFORE ANY CLEANING WORK, ISOLATE FROM THE MAINS SUPPLY

Wait until the fire tray has at least partially cooled.

Plate

Let cool and use wooden spatula to clean plate, then rinse with water or use coarse salt and a rag. Grease and wipe.

Vous pouvez aussi utiliser une éponge à côté abrasif (par exemple Scotch brite®) non métallique et du vinaigre blanc d'alcool pour blanchir la plaque.

CAUTION : Do not use metal utensils or abrasive cleaning products on the hard chromium steel hot-plate.

Body panels :

You can use special-purpose products for stainless steel (e.g. SUMAINOX®, JOHNSON STAINLESS STEEL®, PPZ STAINLESS STEEL®). Never use abrasive products.

CAUTION : Use **NO** chlorinated cleansers to clean this unit.